

»» Solutions for Wear Protection  
in the Cement Industry

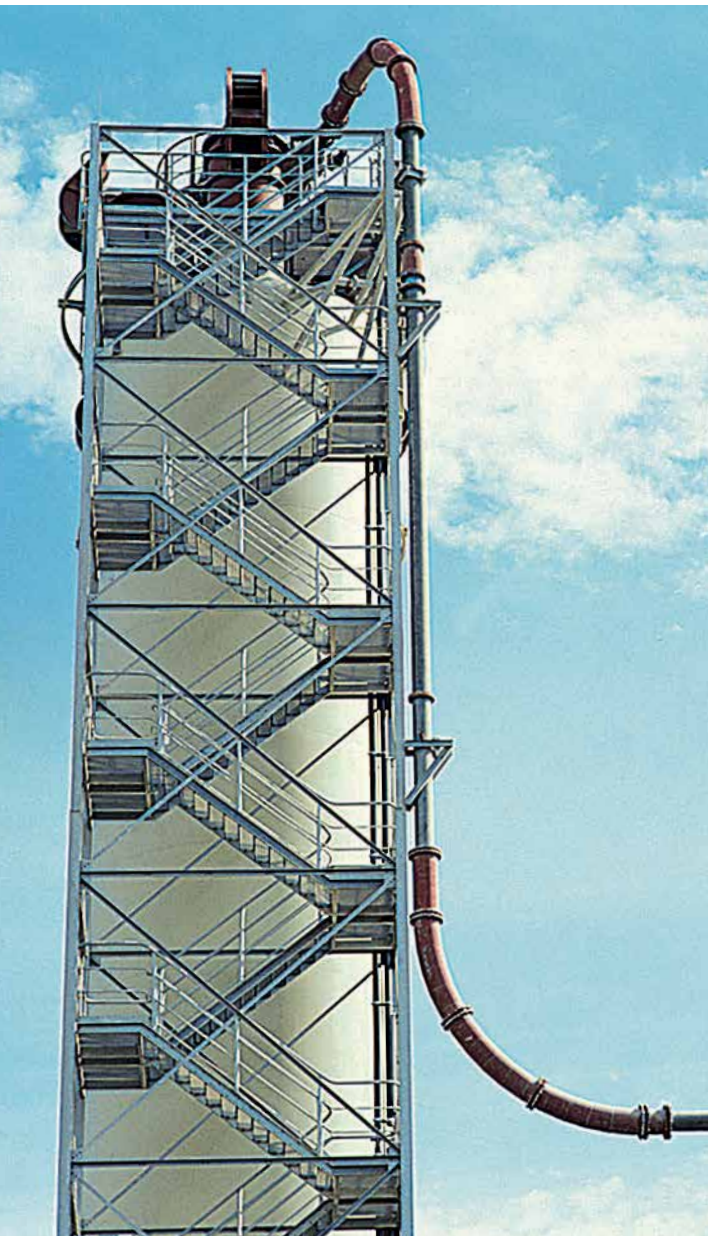

# >> Work with Kalenborn for Your Optimal Solution

## Reduce Costs and Avoid Downtime

Large quantities of bulk material are handled in the conveying and storing systems of cement plants. Unless they are suitably protected these systems will experience frequent failure requiring repair or replacement. Kalenborn offer the complete array of wear protection materials. Depending on the type of installation and the operating conditions, different types of mineral, ceramic and metallic materials, compounds or engineering plastics are used.

In addition, Kalenborn has extensive experience in slide promotion. Interruptions of material flow inside of bunkers and silos must be avoided.



Cooler waste gas pipe lined with KALCRET BNY hard compound



Service by Kalenborn: rebuilding of a grinding roll with KALMETALL W100

### Advantages of Lining Materials:

#### Ceramic Wear Protection

- Very good abrasion resistance
- Tile, cylindrical or jointless lining
- Temperatures up to 1,000 °C/1,832 °F

#### Metallic Wear Protection

- Good resistance against sliding and impact wear
- Thin walls, self-supporting structures
- Good thermal shock resistance

#### Technical Plastic Lining

- Excellent slide promotion for many application
- Good resistance against impact wear
- Low weight

#### Material Combinations

- Optimal wear protection for every application
- Optimized lining cost
- Optimized weight



Feed screw for mill inlet cylinder, protected with KALMETALL W100, diameter 1,350 mm, lining thickness 5 or 8 mm, self-supporting construction

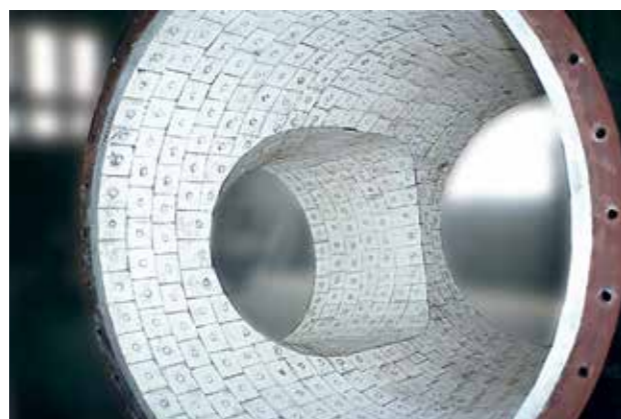

KALOCER high alumina ceramics lining of a separator with mechanically fixed tiles, approx. 100 x 100 mm

# >> Pipes, Components and Service

## Increase Service Lifetimes



Protection for pneumatic and hydraulic pipes



Extended service life of plant components



Kalenborn Service solves wear problems on site

### Less Wear Protection in Cement Production

All sections of cement plants are at risk with regard to wear. This covers the raw material storage and raw material processing. It includes coal pulverizing and injection into the rotary kiln. Furthermore, clinker handling and clinker grinding as well as handling of additives and cement are characterized by the same problems.

Service lifetimes of many years are often achieved with the following materials:

- ABRESIST fused cast basalt
- KALCOR zirconium corundum
- KALCOR-S sintered zirconium corundum
- KALOCER high-alumina ceramics
- KALCERAM wear-resistant hard ceramic
- KALCRET hard compound
- KALSICA silicon carbide ceramics
- KALCAST hard casting
- KALMETALL hard overlay welding
- KALEN slide promotion plastics

In addition, material combinations have been very successful in practice. They enable both technically and economically optimal solutions.

### Wear Protected Components

Components	Lining Materials
Cyclones	ABRESIST, KALCOR, KALOCER, KALSICA, KALMETALL
Fan housings	KALOCER, KALCRET, KALMETALL, KALCAST
Fan rotors	KALOCER, KALMETALL
Gates	KALOCER, KALCOR, KALSICA, KALMETALL, KALCRET
Hydraulic conveyors	ABRESIST, KALMETALL, KALCAST, KALOCER, KALCRET
Mechanical conveyors	ABRESIST, KALOCER, KALCRET, KALMETALL, KALCRET
Nozzles	KALOCER, KALSICA
Pneumatic conveyors	ABRESIST, KALCOR, KALOCER, KALCRET
Pumps	KALSICA
Separators	ABRESIST, KALOCER, KALSICA, KALMETALL, KALCAST, KALCRET
Transfer stations	ABRESIST, KALEN, KALCERAM
Valves and fittings	KALOCER

# >> Solutions for Wear Protection in the Cement Industry

## RAW MATERIAL PREPARATION

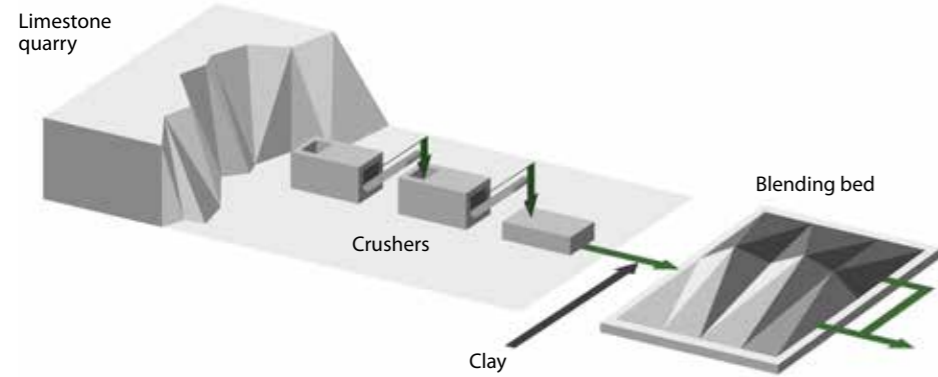

## CLINKER PRODUCTION

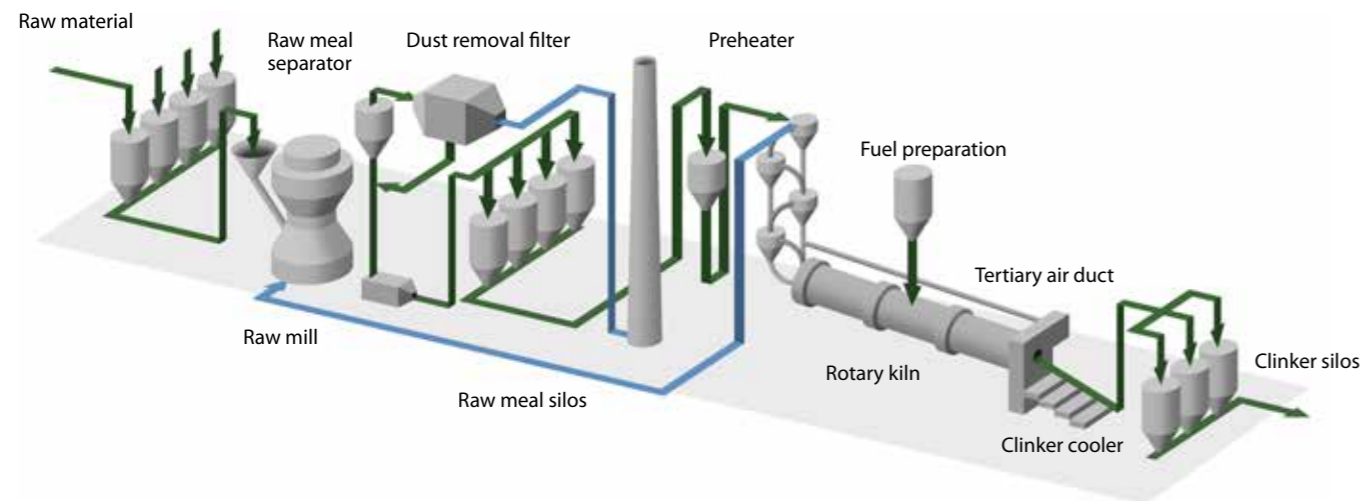

## CEMENT PRODUCTION

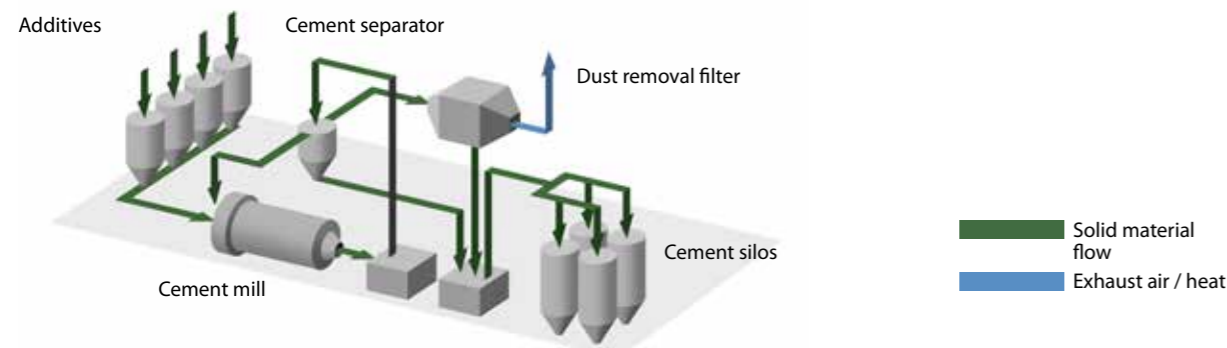

Plant	Components	Material for lining
Crushers	Housing, slides, transfer chutes	KALMETALL, KALCAST, ABRESIST, KALCOR, KALEN
Blending bed	Slides, transfer chutes, mechanical conveyors	KALMETALL, ABRESIST, KALCOR, KALEN

Plant	Components	Material for lining
Raw material	Silos	ABRESIST, KALEN, KALCERAM
	Chutes, transfer chutes, mechanical conveyors	ABRESIST, KALCOR, KALOCER
Raw mill	Vertical mill, ball mill	KALMETALL, KALCAST
Raw meal separator	Separators, cyclones	ABRESIST, KALCRET, KALMETALL, KALOCER
Raw meal silos	Pneumatic raw meal transport	ABRESIST, KALCRET
	Silos	ABRESIST, KALEN
Burners	Pneumatic fuel transport	ABRESIST, KALCOR, KALOCER, KALFLEX
	Burners	KALMETALL, KALOCER
Clinker cooler	Reciprocating grate plates, clinker crusher, chute	KALMETALL, KALCAST
	Dust removal lines, dedusting collection cyclones	KALCRET, KALCOR, KALMETALL
	Tertiary air duct	KALCRET, KALCOR
Clinker silos	Clinker chutes, silos	ABRESIST, KALCOR, KALMETALL, KALCRET

Plant	Components	Material for lining
Material feed	Bunkers, silos, slides	ABRESIST, KALCOR, KALEN
Cement mill	Vertical mill, ball mill	KALMETALL, KALCAST
Cement separator	Separators, cyclones	ABRESIST, KALCRET, KALOCER, KALMETALL
Cement silos	Pneumatic cement transport	ABRESIST, KALCRET
	Silos	KALEN, KALCERAM

## >> Extended Lifetime for Grinding Plants

### Clinker Production



Reliable protection of raw mill and duct system with KALCRET BNX hard compound



ABRESIST used for the center discharge duct of a ball mill

Grinding table segments of a roller mill of 5,000 mm diameter made of KALCAST; smaller parts are cast in one piece



KALCAST C153 hard cast tiles for the protection of grinding roll yokes



Kalenborn supplies grinding rolls, grinding tables and mill linings for grinding plant used for raw material, coal and clinker.  
Top: regeneration of a grinding roll with KALMETALL W100, bottom: newly cast component made of KALCAST C155 hard casting, each 1,500 mm Ø.

## >> Safe with the Handling of Raw Meal

### Clinker Production

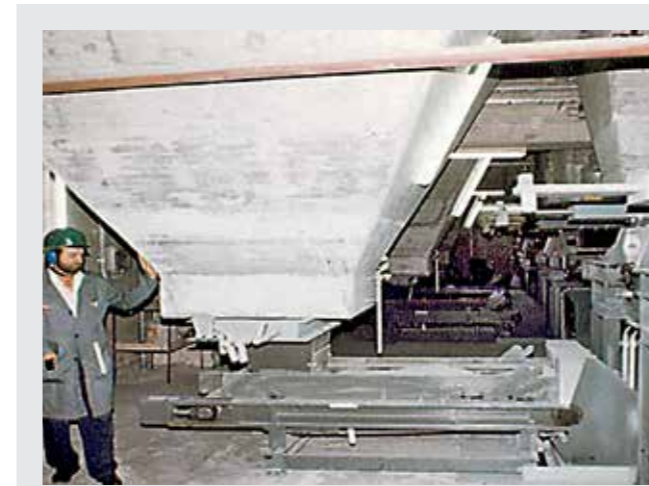

Limestone bunker with slide promoting lining made of KALEN 1006

Protection of a raw meal mill: KALCRET for the duct, KALMETALL W100 for the mill lining



Raw meal transport to the preheater – reliably protected with KALCRET



Pipe diverter in pneumatic pipe lined with KALCOR



Housing made of KALMETAL for a raw meal fan – 2,000 mm Ø – as segment lining

## >> Longlife Pipes and Cyclones

### Clinker Production



Protection of raw meal pipes against abrasive wear with hard compound KALCRET, lining thickness 25 - 40 mm, operating temperature 200 °C / 392 °F

#### Lining of Preheater Cyclones

Solution offered by Kalenborn: prefabricated KALCRET shapes with insulation and mechanical fixing to the steel structure.

This equally ensures:

- high wear protection
- high thermal insulation
- short installation times

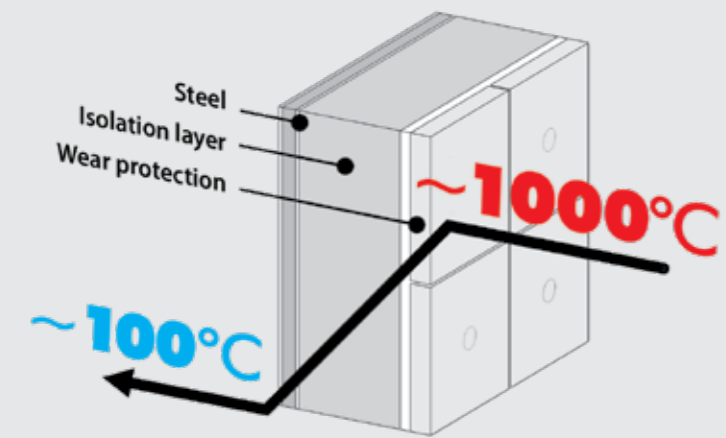

## >> Proven Solutions for Clinker Systems

### Cement Production

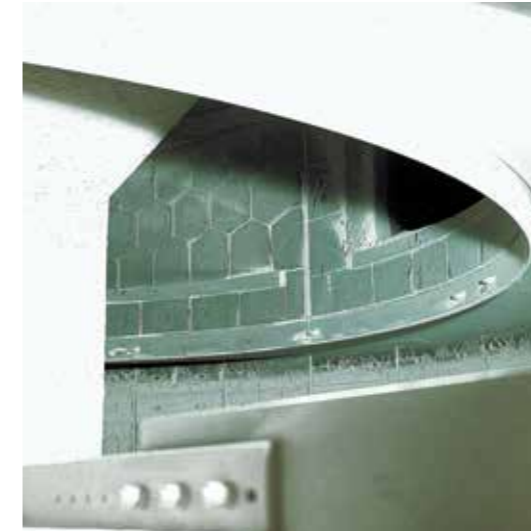

ABRESIST fused cast basalt is a time-tested protective material for cement separators

Separator cones for cement made of KALMETALL W100 6+4, 3,000 mm Ø



Lining pipe parts used for cement grinding with KALCRET BNX, up to 3,200 mm Ø

Precise fitting of KALOCER high alumina ceramics, 13 and 25 mm thick

## >> Transport Pipes, Pipe Bends and Chutes

### Cement Production



Transport pipe to the cement silos; the bends are protected by ABRESIST



Pipes used in the cement industry are reliably protected with ABRESIST, KALCRET or – in case of extreme wear – with KALCOR and KALOCER



Pipe for clinker transport made of KALMETALL W100, 300 mm Ø

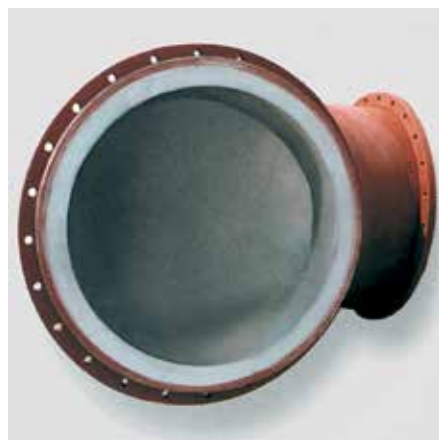

Jointless lining with KALCRET, even for asymmetric cross sections

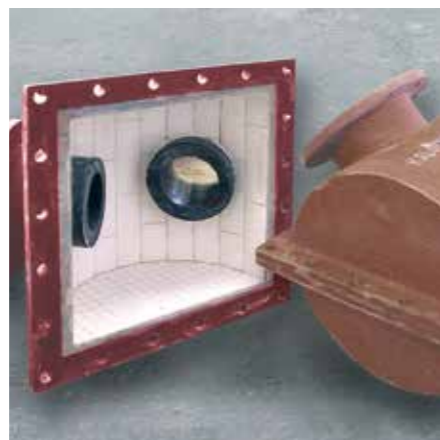

Kalenborn deviation pots installed in case of narrow space



KALCOR S allows long duty cycles and high temperature stress

## >> Materials at a Glance



### ABRESIST Fused Cast Basalt

ABRESIST is a basalt based wear protection for plant components in which the material to be conveyed predominantly causes friction induced abrasion in bunkers, troughs, chutes, chain conveyors, mixers, separators, pipes, pipe bends, cyclones, etc.

**Installation:** the shaped cast tiles are laid in cement mortar. To meet special requirements other setting materials may be used, such as KALFIX synthetic mortar or potassium silicate based mortar for higher temperatures.

**Application temperature:** up to approximately 350 °C / 662 °F.  
**Advantages:** high abrasion resistance, lasting smooth surface, no corrosion.



### KALCOR Zirconium Corundum

KALCOR is a material composed of alumina and zirconia. It is recommended for particularly high abrasion and/or thermal stress, e.g. in cyclones and separators, in chutes for hot sinter or clinker, for mixers, pipelines, etc.

**Installation:** the shaped cast tiles are laid either in cement mortar or special setting materials. Mechanical fixing is possible as well.

**Application temperature:** up to approximately 1,000 °C / 1,832 °F.  
**Advantages:** high abrasion resistance, high temperature stability, resistant to impact and corrosion.



### KALOCER High Alumina Ceramics

Special high alumina ceramics for system components exposed to extreme wear and/or thermal stresses for which thin linings or smooth surfaces are required, such as in circulating air separators, cyclones, screw centrifuges, vibrating chutes, fans, fan blades, etc.

**Installation:** shaped elements or thin tiles laid in epoxy mortar. KALOCER tiles are also vulcanized into rubber mats to be fastened by adhesive. Mechanical fixing is possible as well.

**Application temperature:** up to approximately 1,000 °C / 1,832 °F.  
**Advantages:** high abrasion resistance, high temperature stability, resistant to impact and corrosion. Available in thicknesses from 1.5 mm.

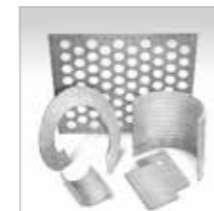

### KALMETALL and KALCAST Metallic Wear Protection

Metallic wear protection is offered in various qualities. It is particularly suitable as protection against sliding and impact wear. The range includes hard castings as well as overlay weldings.

**Installation:** Made-to-measure castings laid in setting compounds or mechanically fixed. Plates with overlay welding are fixed mechanically or designed as self-supporting structure.

**Application temperature:** up to approx. 350 °C / 662 °F (hard castings), up to 750 °C / 1,382 °F (hard overlay weldings).  
**Advantages:** highly wear resistant and resistant against impact wear, castings economic upon series production, overlay weldings characterized by good adaptability.



### KALCRET Hard Compound

Cement bonded hard compound for continuous lining of plant components where high wear and temperature occur, e.g. troughs, chutes, bunkers, cyclones, etc.

**Installation:** by trowelling, casting or spraying.

**Application temperature:** up to approximately 1,200 °C / 2,192 °F.  
**Advantages:** high wear resistance and compressive strength, jointless lining and highly temperature resistant.

